

# Technical Information

## Codes and Standards

### Design Compliance

Design loadings accord with the following:-

The Building Regulations England and Wales,

The Building Regulations Scotland,

Irish Standard 193: Timber trussed rafters,

BS 6399: Part 1: Code of practice for dead and imposed loads,

BS 6399: Part 3: & amendments: Code of practice for imposed roof loads,

BS 6399: Part 2: Code of practice for wind loads.

Timber designs accord with the following:-

BS5268:-2: Structural use of timber, code of practice for permissible stress design, materials and workmanship.

BS 5268-3: Code of practice for trussed rafter roofs.

Connector plate design accord with the following:-

British Board of Agreement Certificate No: 90/2386,

WIMLAS Certificate 038/96 - MiTek M20 punched metal plate timber fasteners.

## Timber

The timber used in the manufacture of trussed rafters in the UK and Eire is strength graded softwood.

The common sources of supply for the timber are Scandinavia, Baltic States, Canada and the USA. The last two countries provide only a minor proportion of the timber used in trussed rafters.

Timber is classified by either strength grade or strength class and this classification defines the working stresses which may be used to design with the particular timber involved.

Grading may be either manual, by trained graders, or mechanical, by use of a strength grading machine.

Machine strength graded timbers form the majority of timbers used in trussed rafters.

As each particular length of timber is classified, a grading mark or stamp is applied to show its classification.

When the timber is re-cut for use in trusses, the

Trussed Rafter Fabricator will mark the finished truss with the grades or strength classes of timber used, often by means of a label attached near the apex of the truss or by means of a stamp on the timber near the apex.

Maximum timber lengths of up to 6 metres are used, although lengths of 4.8 metres are commercially more common. This means that splice joints are frequently required in truss chord members, to achieve long spans. Please refer to section 2.4 concerning timber splicing.

The Designer will use the strength grade or strength class values when designing the members forming the truss. (See section 2.4, Design Method).

British Standard BS4978: - Specification for visual strength grading of softwood. BSEN 1313 - 1: Permitted deviations and preferred sizes of softwood sawn timber, together with BS 5268 - 3: Code of Practice for trussed Rafter Roofs govern the grading, sizing and use of the softwoods used in Trussed Rafter construction

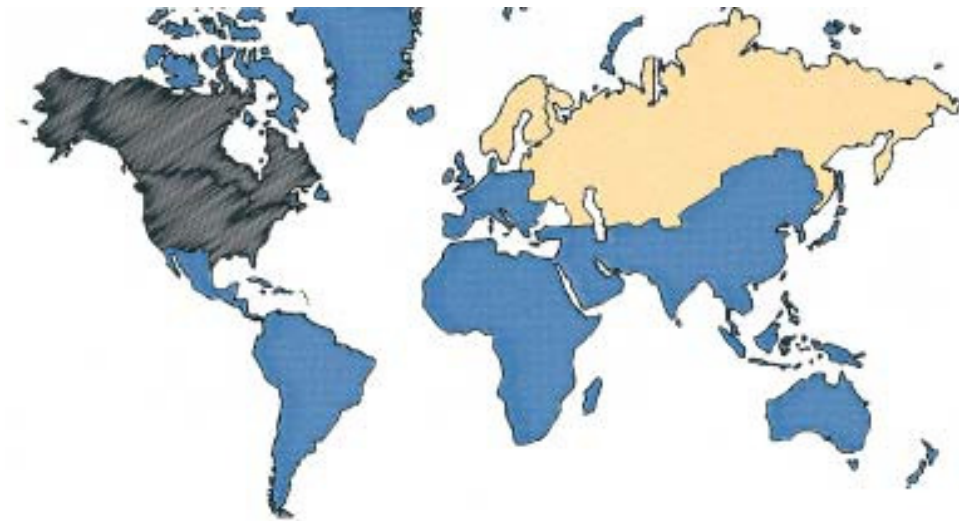

### Connector Plates

MiTek connector plates are manufactured from structural grade galvanised mild steel.

Many common types of nailplate are currently used in the UK and Eire: The 1.0mm M20, the 1.2mm B90, the 2.0mm M200 and several special plates including field splice plates.

For full details of the use of each type of nailplate, please refer to Agreement Board Certificate 90/2386, and Wimlas Certificate 038/96.

The difference in the formation of the nails (teeth) produced by the stamping-out process for each type of plate, together with the difference in steel

thickness and width used, produces a varying set of design parameters for each type of plate. Further, a large range of available sizes for each type of plate provides the designer with a very flexible system for the design of each particular joint.

To cater for the aggressive roof environments found in industrial or agricultural buildings, or for decorative purposes in exposed trussed situations, a reduced range of sizes with the M20 nail configuration is available in 20 gauge Stainless steel. Please note, however, that these are likely to add considerably to the cost of the finished roof trusses.

Figure 20

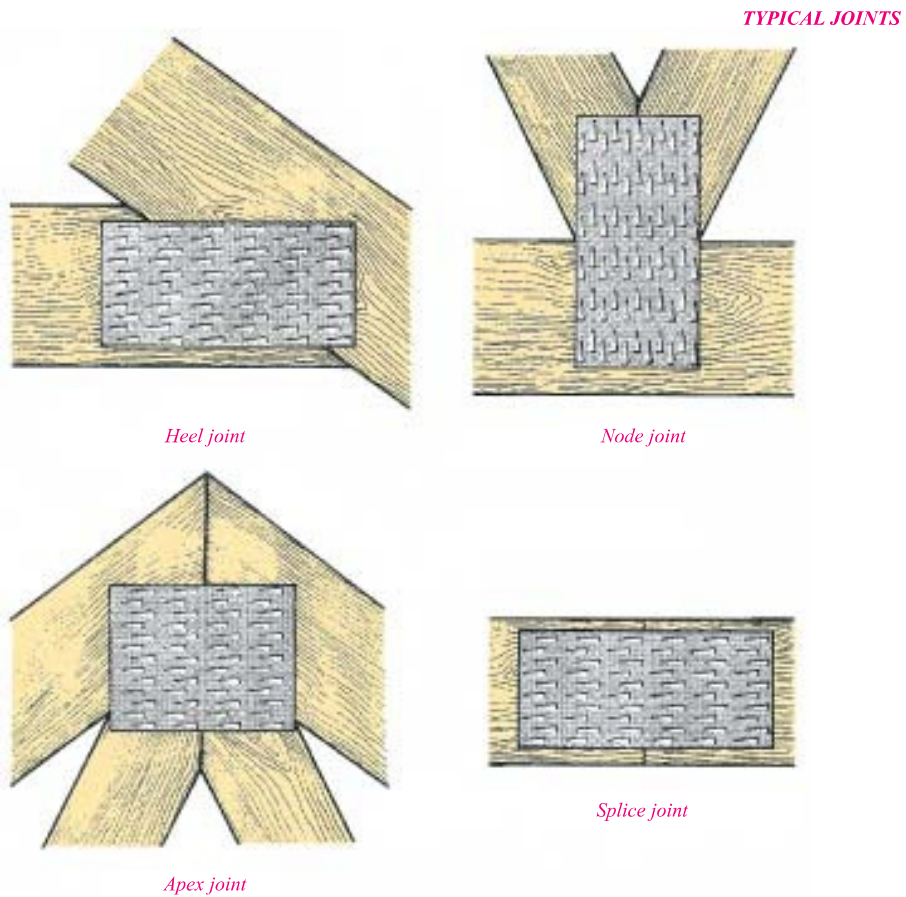

### Design Method

A trussed rafter is an engineered framework consisting of structural members forming triangles. The framework derives its inherent strength from this triangulation.

The members around the perimeter of the trussed rafter are known as chords (top and bottom, also called rafters and ceiling ties), and the internal members providing the internal triangles are known as webs (sometimes also called struts and ties).

A true trussed rafter is formed only when the webs form triangles between the top and bottom chords. Attic frames and Raised-Tie trusses (see section 1.7 and 3.16) do not provide this triangulation and are therefore technically not trussed rafters.

When designing non-standard trussed rafters, it is beneficial to ensure the full triangulation as above, please refer to MiTek's System Design Office if in doubt.

### Principles of Design

When loading is applied to a trussed rafter (from tiles, ceiling construction snow etc), two main kinds of force are generated in the members:

1. Bending Moment
2. Axial Force

Bending moment causes neighbouring sections of timber to tend to rotate relative to each other (see figure 21a).

Axial force may be either tensile, i.e. pulling adjoining sections of timber away from each other, or compressive, i.e. crushing adjoining sections of timber into each other (see figure 21b and 21c).

A compressive force may cause the member to buckle (bending sideways out of the plane of the trussed rafter) and this may need to be counteracted by bracing (see sections 2.5 and 3.7) or by increasing the section of timber required for the affected member.

Within a trussed rafter, members will be subject to either axial force alone or a combination of axial force and bending moment. The design of a trussed rafter must allow for these effects, together with the differing forces produced by different types of load (see section 2.7 on Loading and Load cases.)

Figure 21a

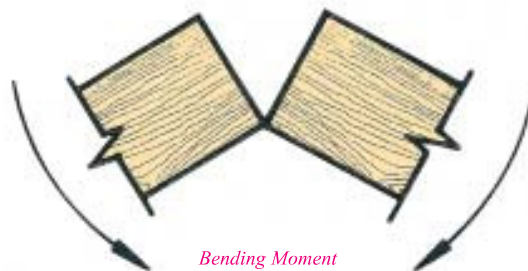
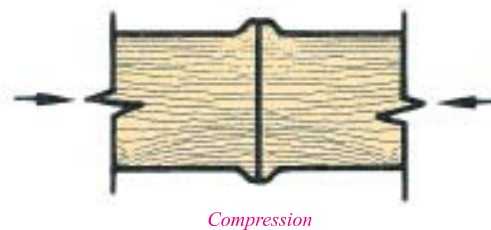

Figure 21b



Figure 21c



## Design Method

### Bending Moments

Bending moments are generally induced in the Chord members due to the loadings (tiles, ceiling, snow etc) placed directly onto them. It is unusual for Web members to be subject to bending moments.

The magnitude of the bending moment in a particular chord is largely due to the Panel Length (the distance between the joints at each end of the member, usually measured horizontally, also known as the Bay

Length). The general rule is, the longer panel length the greater the bending moment and hence the larger the section of timber required to safely resist the bending moment.

Further, BS. 5268-3 defines the maximum bay lengths permitted in Table 3, a copy of which is given below:

**BS 5268 Table 3: Maximum Bay Lengths of Rafters and Ceiling Ties**

Depth of member	Maximum length (measure on plan between node points)			
	35mm thick		47mm thick	
	Rafter	Ceiling Tie	Rafter	Ceiling Tie
Mm	m	m	m	m
72	1.9	2.5	3.3	3.3
97	2.3	3.0	3.6	4.3
120	2.6	3.4	3.9	5.0
145	2.8	3.7	4.1	5.3

The choice of a different truss type, with a smaller panel length (and hence more webs), will usually yield a smaller section of timber required.

The method of calculation relating to bending moment is as follows:

The applied bending stress (calculated from the bending moment divided by the section modulus of the timber being considered) is compared with the permitted bending stress for the particular timber

grade or strength class.

The resulting ratio:

$$\frac{\text{Actual bending stress}}{\text{Permitted bending stress}} < 1$$

This ensures that the actual bending stress in the timber cannot exceed the permitted stress, causing the timber to fail.

### Axial Force

Axial forces within the trussed rafter are calculated by analysing the whole frame. The greater the number of panels (webs) the greater the axial forces can be. Also, the lower the pitch of the top chord the greater can be the axial force.

As mentioned previously, axial force can be either tensile or compressive and, if compressive, can lead to problems with out-of-plane buckling.

In a similar way to bending moment, the actual axial stress in the timber (calculated from the axial force divided by the area of the timber section), is compared with the permitted axial stress of the timber grade or strength class being used.

This ensures that the timber never exceeds its permitted axial stress limit.

Generally, web members will be subjected only to axial force, whereas chord members will be subject to a combination of bending and axial stresses.

For chord members therefore, the calculation becomes:

$$\frac{\text{Actual bending stress}}{\text{Permitted bending stress}} + \frac{\text{Actual axial stress}}{\text{Permitted axial stress}} < 1$$

To ensure that the timber section is within its defined limits for both bending and axial stress.

This ratio is known as the combined stress index (CSI) or stress summation.

$$\frac{\text{Actual axial stress}}{\text{Permitted axial stress}} < 1$$

## Design Method

### Deflection

Another important criterion in the design of trussed rafters, which must be considered, is the amount of deflection, or movement of the truss when loading is applied to it. (See figure 22).

BS.5268-3 section 6.5.7 clearly defines how to calculate deflection and the permissible limits on rafters, ceiling ties and on overhangs and cantilevers.

Figure 22

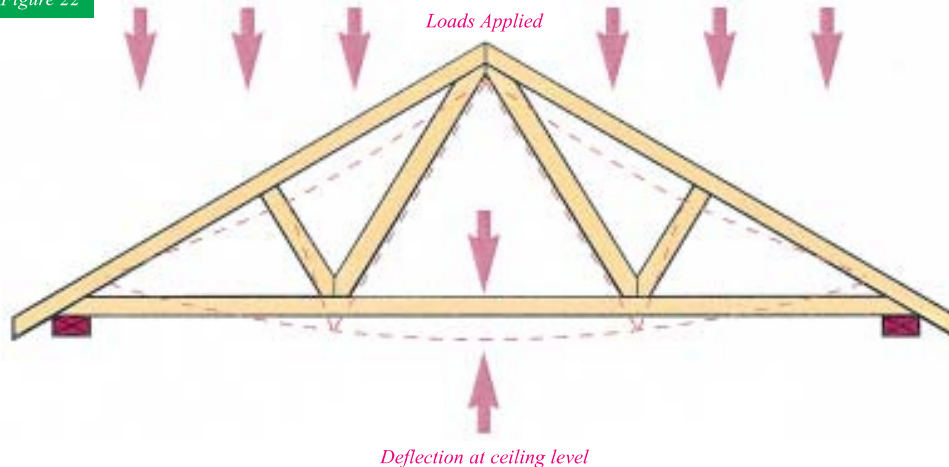

This therefore defines the amount of movement under the differing load conditions permitted.

Additionally, the Trussed Rafter Designer should be aware of the problems which may arise due to **DIFFERENTIAL DEFLECTION**.

Differential deflection may occur between two adjacent trusses within a roof when either the support conditions or the loading conditions change. For example, in a hip end or corner condition (see sections 2.8 and 3.5) the heavily loaded girder truss may show more anticipated deflection than the truss immediately behind it in the hip sequence. Or, where a bobtail (stub) truss is used adjacent to a full span truss, the deflection of the standard truss may be anticipated to be greater than that shown for the bobtail.

In this situation, the Designer should ensure that the difference in anticipated deflection between the two trusses is kept within limits, to avoid problems in producing a smooth line for the ceiling constructions underneath.

This problem of differential deflection between adjacent units is one of the most common causes of site problems and, once the roof is erected, one of the most difficult to rectify. The remedy is for the Designer to be fully aware of the potential problem *at the design stage*.

Figure 23

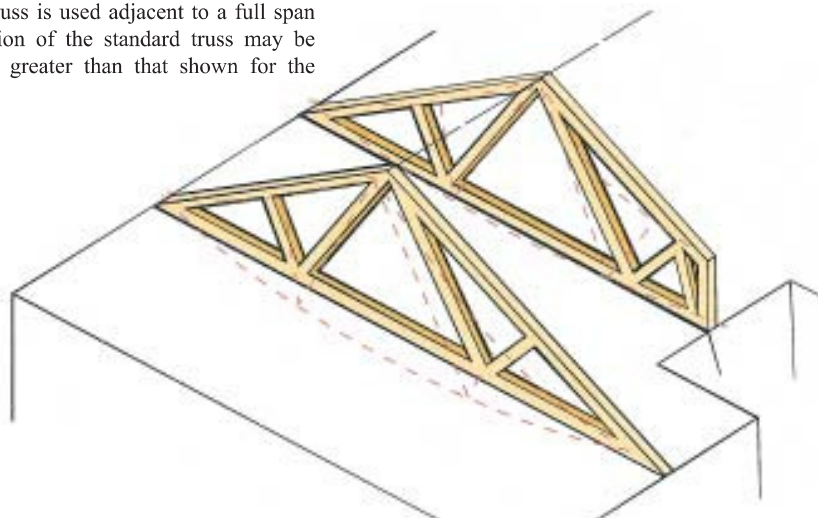

### Design Method

The design of joints using Mitek nailplate connectors is governed by the British Board of Agreement Certificate 90/2386 and WIMLAS Certificate 038/96.

Within the approval certificates the conditions of use, assessment of fitness for purpose, sizes of available nailplates, methods of joint assembly, relevant loadings etc are specified. It is not intended in this document to reproduce in part or in whole the contents of the Certificates; copies of these are available on request from MiTek.

However, to give an insight into the method of joint design using the nailplates, the Designer should note that each nailplate joint must be assessed for shear

strength and lateral resistance to the forces placed upon its integral teeth.

The values for shear and tensile strength are given in the relevant Certificate, as are the values for the nail anchorage loads. It should be noted that the lateral resistance of a nailplate joint depends upon:

1. The number of effective nails in the joint.
2. The species of timber used and its condition (moisture content).
3. The duration of the loading applied.
4. The direction of bearing of the nails in relation to the grain of the timber (load to grain).
5. The direction of the loading in relation to the connector plate (load to nail).

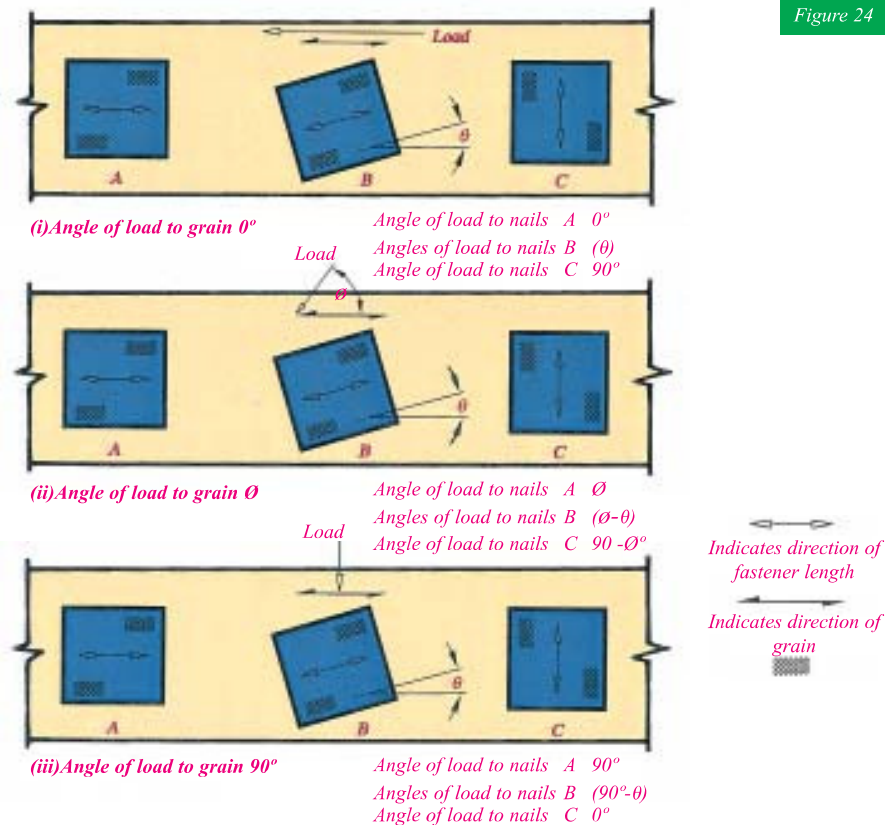

It should be noted that, when designing a nailplate joint, the approval Certificates define certain ineffective areas at the ends and edges of the timber in which the nails are to be ignored for the design.

Further, the species of timber used and the duration of loading causing the forces must be taken into account.

Finally, the actual position of the nailplate on the joint will affect the permitted values for each nail.

It can be seen that this leads to a highly complex interaction, as several different load durations, combined with a number of possible nailplate orientations and a large number of available sizes of nailplate makes the most economical choice of any particular nailplate a difficult decision.

By its nature, the solution of this interaction is now largely handled by MiTek's sophisticated computer programs although manual design is still necessary for very special applications.

### Design Method

#### Splice Joints

Due to the need to make long span trusses from shorter lengths of timber, butt joints called SPLICES often need to be introduced in the top and bottom chord members.

between 10% and 25% of the panel length in which the splice occurs for triangulated trussed rafters. In other frames and when splices are outside of the code 'zone' the software will design the splice to resist shear, axial and moment forces.

These joints, like all other nailplate joints, need to be properly designed in accordance with the above factors. Splice joints will normally occur in positions

Some typical joint details are given in figure 25.

Figure 25

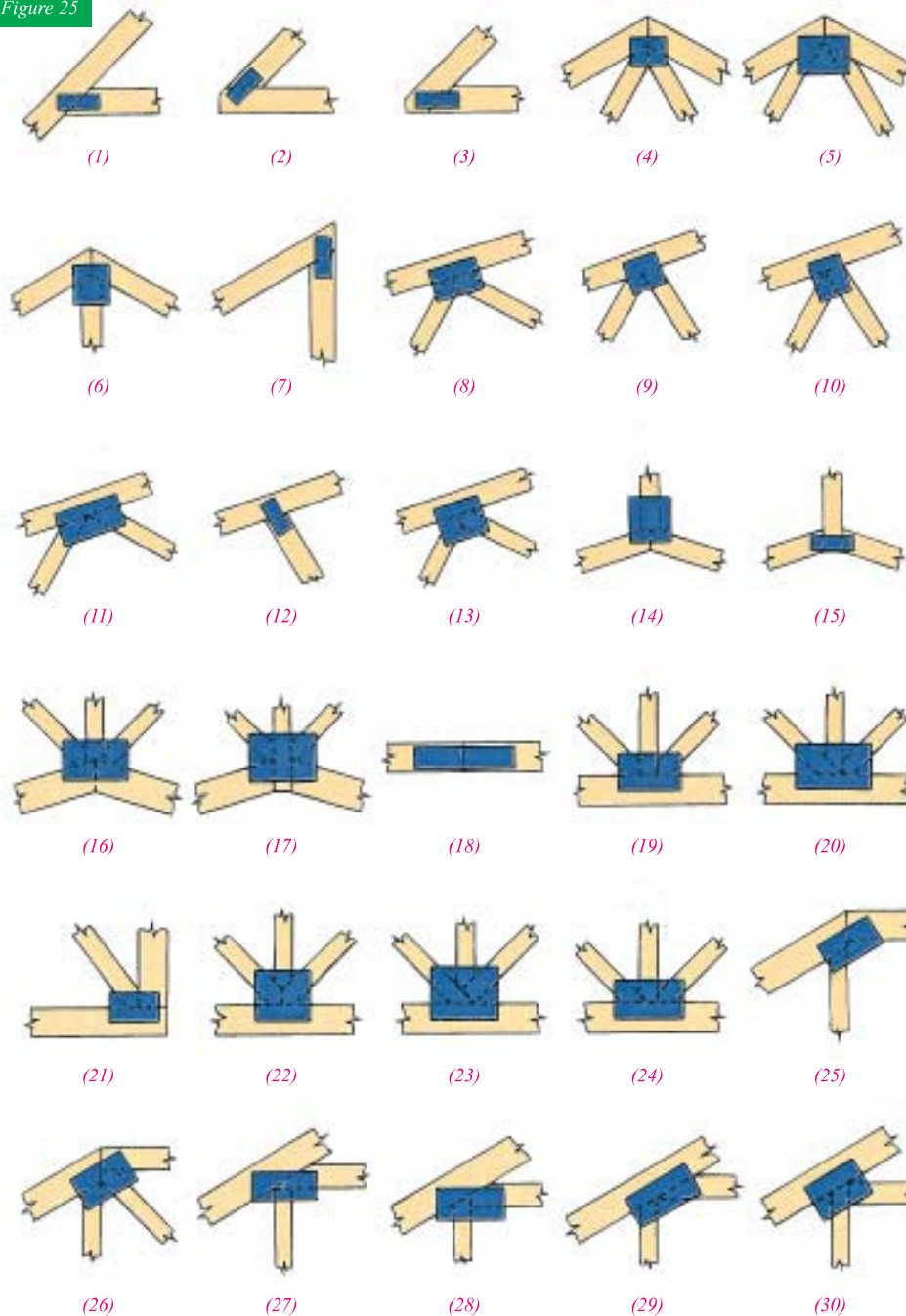



### Roof and Trussed Rafter Bracing

Bracing in trussed rafter roofs is essential and performs specific and separate functions:

#### 1. TEMPORARY BRACING

Temporary bracing is required during erection of the trussed rafters to ensure that the trusses are erected vertically plumb, at the correct centres and in a stable condition for the continuation of construction.

This bracing is the responsibility of the roof erector, (see later for recommendations).

#### TRUSS INTEGRITY BRACING (Specified by Trussed rafter Designer)

#### 2. TRUSS INTEGRITY BRACING

Bracing may be required by the trussed rafter design to prevent out-of-plane buckling of a member or members within the truss. This bracing must be provided to ensure the structural integrity of the trussed rafter. It is the responsibility of the Trussed Rafter Designer to inform the building designer if this is required.

See figure 26a, 26b and 26c.

Figure 26a

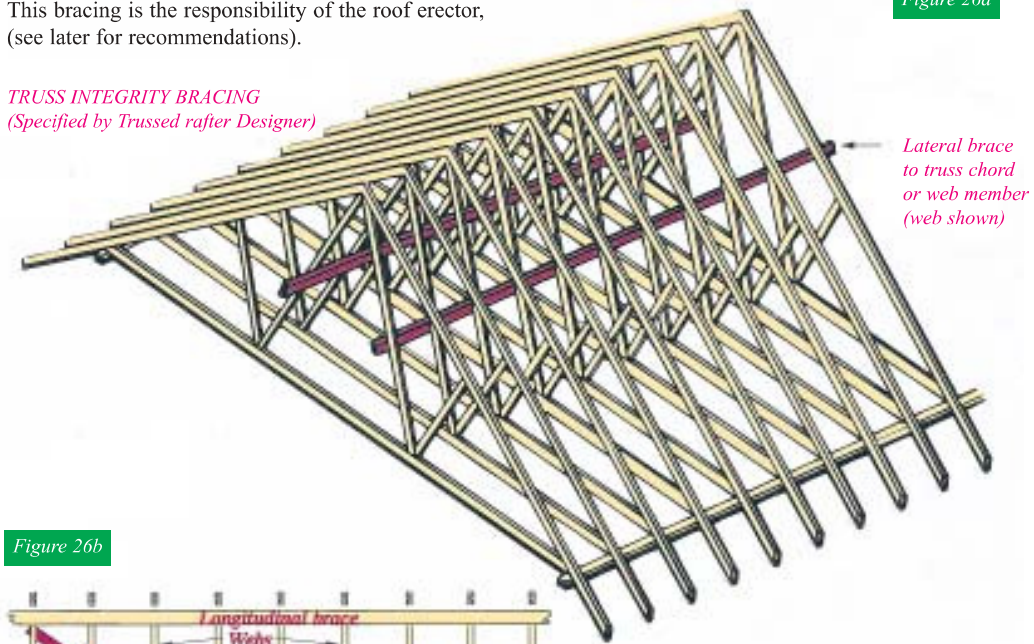
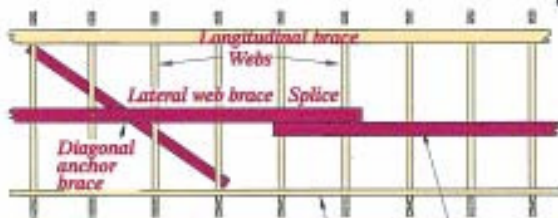

Figure 26b



#### LATERAL WEB BRACING

One shown (with splice) at mid point of webs. For two braces, locate at third-point of webs. Diagonal anchor braces as shown at 6m intervals. All braces 25 x 100 free of major defects and fixed with two 3.35 x 65mm galvanised nails at all cross-overs.

Figure 26c

#### ALTERNATIVE WEB STABILITY BRACE (use when less than three trusses in line)

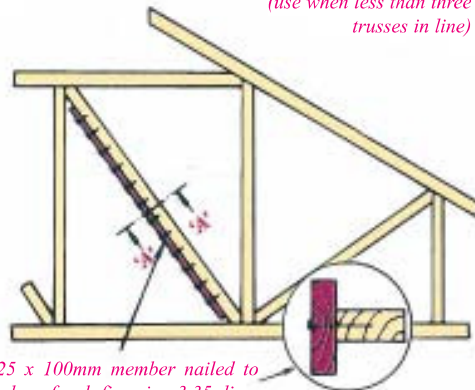

25 x 100mm member nailed to edge of web fix using 3.35 dia x 65mm long R/W galvanised nails, at 150mm centres.

Section A-A

#### 3. ROOF STABILITY BRACING

In addition to the above bracing, extra bracing will often be required to withstand external and internal wind forces on the walls and roof. This area of bracing design is the responsibility of the Building Designer (or Roof Designer if one has been appointed) and includes such areas as diagonal wind bracing, chevron bracing to internal members, longitudinal bracing at truss node points, etc.

### Roof and Trussed Rafter Bracing

Figure 27a

(Specified by the building or roof designer) for guidance only please refer to BS5268-3.

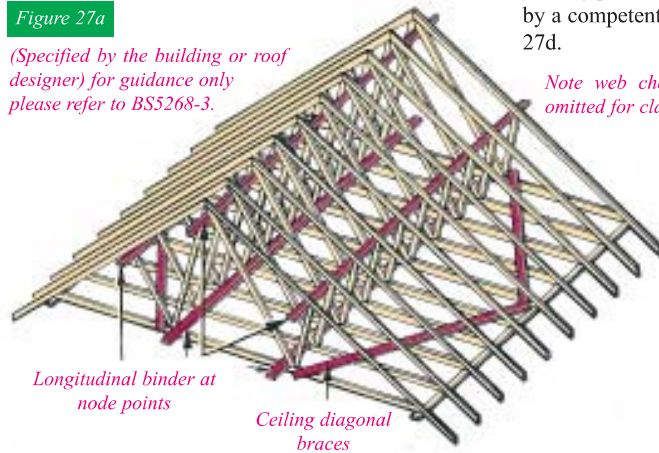

BS.5268-3 gives some recommendations for certain specific cases of roofs; for other types of roof the bracing pattern for roof stability should be designed by a competent person. See figure 27a, 27b, 27c and 27d.

Note web chevron and rafter diagonal bracing omitted for clarity, see following details.

Figure 27b

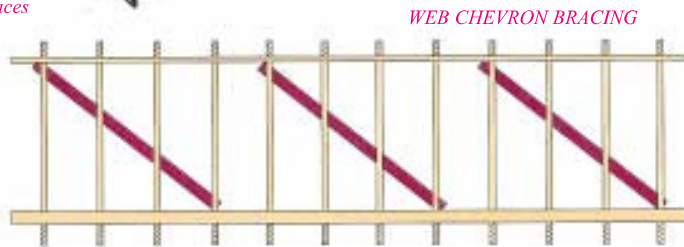

Should be inclined at approximately 45° and each nailed to at least three trusses. All 25 x 100mm free of major defects and fixed with 3.35 x 65mm galvanised nails at all cross-overs.

Figure 27c

RAFTER DIAGONAL BRACING

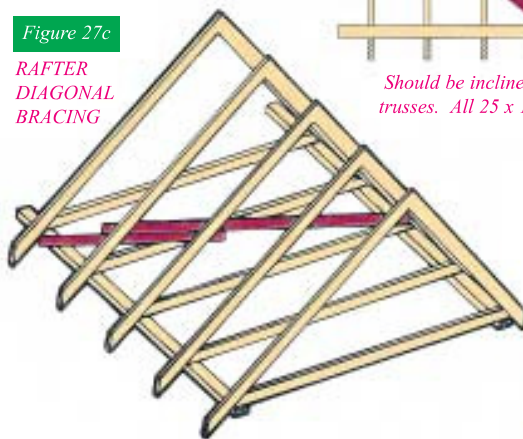

(One only shown and spliced) webs and all other bracing omitted for clarity. Braces to be 25 x 100mm free of all major defects and fixed with two 3.35 x 65mm galvanised nails at all cross-overs including wall plate. Braces to be included at approximately 45° to the tiling battens and repeat continuously along the roof.

Figure 27d

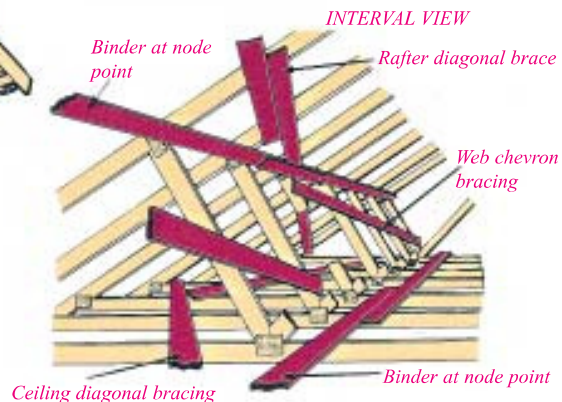

#### Design responsibility

Specifiers and designers should understand that Truss integrity bracing is the responsibility of the Trussed Rafter Designer who must inform the Building Designer if such bracing is required. Whereas Roof Stability bracing (and any additional specialist bracing) is the responsibility of the Building Designer (or Roof Designer if one has been appointed). The Building Designer is responsible for detailing ALL bracing.

The Building Designer has access to information pertinent to the structure i.e. walls, and the forces being transferred from them, which the Trussed Rafter Designer cannot determine. (See also section 1.2 on Design Responsibilities).

Please refer to BS 5268-3 for further guidance on bracing of roofs for domestic situations.

## Loading and Load Cases

It is important that all truss loadings are specified before quotation to ensure correct design. Unless

otherwise advised, trusses will normally be assumed to be for normal domestic use.

### Loadings for Domestic Use

The great majority of trusses fall into this category. The relevant document, BS 5268-3 describes the minimum loadings which should be taken into account.

The following data provides a useful guide to typical loading factors in roof design:

## TOP CHORD (Rafter)

### Tiles

Weight to be as laid. Nearly all commonly used interlocking concrete tiles are within  $0.575\text{kN/m}^2$ , which is regarded as the standard loading. It is important that the actual tile weight to be used is notified to the Trussed Rafter Designer. This loading is specified as a long term loading on slope; i.e. applied along the length of the sloping rafter.

### Felt, Battens, Self Weight

The allowance usually made for felt, battens and self weight of trusses is  $0.11\text{kN/m}^2$ .

As are the tiles, this is regarded as a long term loading slope.

### Wind

Except in the case of vertical and near vertical chords, wind loading is not often a critical criterion in the design of fully triangulated trusses.

All trusses should be designed for wind loading in accordance with BS 6399: Part 2 code of practice for wind loads. Wind load data should be provided by the Building Designer to the Trussed Rafter Designer.

Wind loading is treated as a very short term loading, applied at right angles to the relevant members.

### Snow

Designs for snow loadings are in accordance with BS 6399: Part 3: Actual design loads are dependant upon several factors, such as building location, altitude and roof plane geometry. The loadings imposed by snow are regarded as medium term loadings, on slope. Where appropriate, snow drifting should be considered.

### Man Load on Rafter

This is specified as  $0.75 \times 0.9\text{kN}$  in any position. Test have shown that, in normal circumstances, tiles and battens provide sufficient transverse load distribution for this loading not to be a critical criterion in design. However it can dictate the design of a long overhang. This loading is treated as short term loading.

## BOTTOM CHORD (Ceiling Tie)

### Plasterboard, Self Weight etc

The standard ceiling construction of one layer of 12.5mm plasterboard and skim coat is taken as giving a load of  $0.25\text{kN/m}^2$  (including truss self weight).

This load is treated as a long term loading on slope (although generally bottom chords will have no slope).

### Light Storage

For normal domestic applications, the specified allowance for storage over the length of the bottom chord (ceiling tie) is given as  $0.25\text{kN/m}^2$  (on slope). For anything other than this condition, the Building Designer should inform the Trussed Rafter Designer of the required storage loads to be used.

This load, as for the ceiling construction load, is treated as a long term loading on slope.

### Man Load on Ceiling Tie

To allow for loadings imposed by a person working in the roof void, an allowance of  $0.75 \times 0.9\text{kN}$  at any location on the bottom chord, either in the bays or at the node points (joints) should be made. This loading is treated as short term loading.

## Loading and Load Cases

### Loadings - Water Tank

Water tanks in trussed rafter roofs should be supported by a system of bearers and cross-bearers in such a fashion that the loadings imposed on the trusses are transferred to a position as close as possible to the node points (joints) of the trusses. The standard 230 litre water tank is usually supported over three individual trusses, or 300 litre tank over four trusses. The long term loading from this arrangement is taken as 0.9kN/truss (0.45kN per node).

### Loadings - Agricultural Buildings

Loadings for agricultural buildings are described in BS 5502 and are based on weight of the actual materials in the fabric of the building. Snow and wind loading criteria depend on occupancy classification determining the acceptability of collapse and expected life of the building.

Compliance with BS 5502 has been a condition of obtaining certain capital grants and an up-to-date briefing on the matter should be obtained before specification.

### Purlins

Trussed rafters are generally used in conjunction with tiling battens fixed to the upper edge of the top chords and this provides an excellent method of out-of-plane restraint to the top chords. If tiling battens are not to be used, it is vital to specify the maximum purlin spacing to be used for two reasons:

- 1.To allow the Trussed Rafter Designer to apply the loads in the correct way.
- 2.To allow the Trussed Rafter Designer to apply correct top chord restraints.

The Trussed Rafter Designer will require this information in order to obtain a correct design.

### Load Duration (load cases)

The load-carrying characteristics of timber are such that it can sustain heavier loading for a short time than it can for a long time.

This effect is used in establishing the allowable structural properties of a particular timber grade (or Strength Class).

Trussed rafters and other structural timber components are then designed taking into account the differing durations of the various loadings which they are required to carry.

The main loadings encountered in dealing with trussed rafters (see earlier in this section) are:

#### 1.Roof Coverings:

Tiles, slates etc. are considered as long terms loads, as they will be present throughout the life of the building.

#### 2.Ceiling Construction:

Plasterboard etc at ceiling level is, like the roof covering, considered as long term.

#### 3.Ceiling Storage:

The allowance for storage in the roof void at ceiling level is also treated as an ever-present, long term load.

#### 4.Water Tanks:

As these will also be present throughout the building's life loads applied by water tanks are treated as long term loads.

#### 5.Snow Loadings:

The design allowances for loadings due to snow on the roof are treated as medium term loads, i.e. these loads will not be present at all times, but will affect the roof structure only for a period of weeks or months at a time.

#### 6.Man Load on Rafter and Ceiling:

Where this is applicable, this load is treated as a short term load, ie this load will be present within the structure for a period of minutes or hours only.

#### 7.Wind Loadings:

Always considered for design, the loadings due to wind are treated as very short term loads. These loads will be present on the structure for a period of minutes or seconds only.

The above loadings cover the most usual types of load carried by trussed rafters.

Other loads may be present within the roof in special circumstances These may include air conditioning equipment, patient hoists, climbing ropes etc and must be allowed for in the design, in the appropriate load case.

## Loading and Load Cases

The load cases which normally dictate the results are:-

### 1. Long Term

Designing for the effect of all long term loads (all loads which will be present throughout the life of the building) i.e.:

- Roof coverings
- Ceiling constructions
- Ceiling storage
- Water tanks
- any special long term loads.

Figure 28a

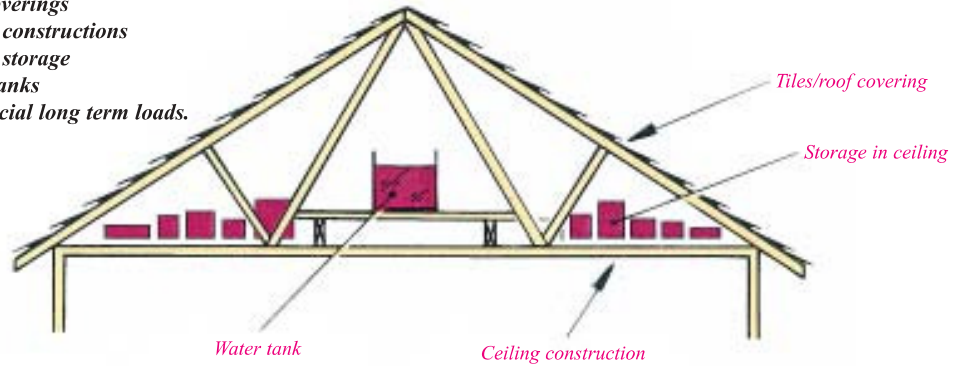

### 2. Medium Term

Taking into account loads which will be present for a period of weeks or months on the building i.e. - *All the long term loads Plus - snow loads*

Figure 28b

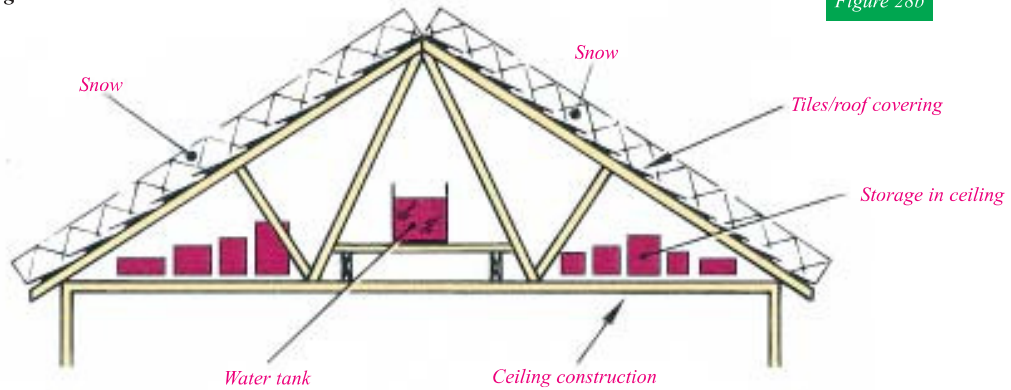

### 3. Short Term

For loads which may occur for minutes or hours during the buildings life i.e.:

- All the long term loads
- Plus - Snow loads
- Plus - The man load on the bottom chord

It will be seen that this load case will, in fact, be a multiple load case as the man load must be checked at every bottom chord bay and node position. Note the man load on top and bottom chords are in separate load cases.

Figure 28c

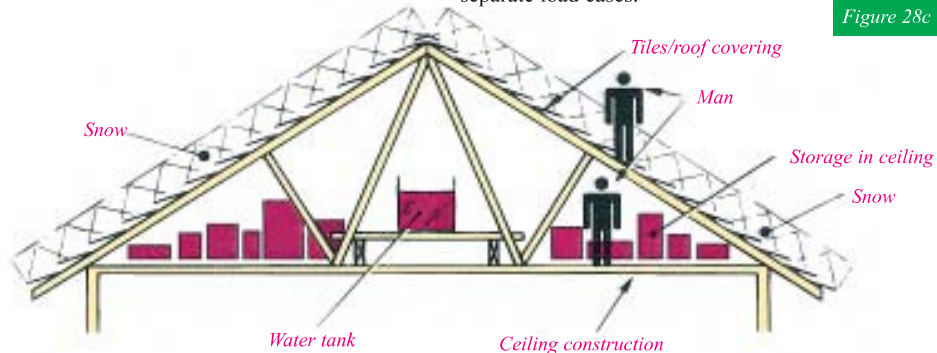

Full details of load cases see BS 5268-3

### Selecting Trussed Rafter Profiles

Determination of the required truss rafter profile assumes the ability to read a two dimensional drawing and visualise the required structure in three dimensions.

This skill is acquired by experience, although certain powerful graphical aids in the form of computer programs are now available to assist the designer in this area.

The designer's task is to take the roof plans, sections and elevations presented to him by his client and form the required roof shape in his mind. The technique of 'sectioning' the roof will then give the

required profile of the truss required at any point.

'Sectioning' requires the designer to consider the height dimension of a particular point on the roof line, as well as its plan position. The profile change points for a truss are often seen on the roof plan as hip or valley intersection lines, or at points where the apex or eaves line changes in some respect.

The following figures illustrate the transition from two-dimensional roof plan to three-dimensional impression of the roofscape to the required trussed rafter profiles.

ROOF PLAN

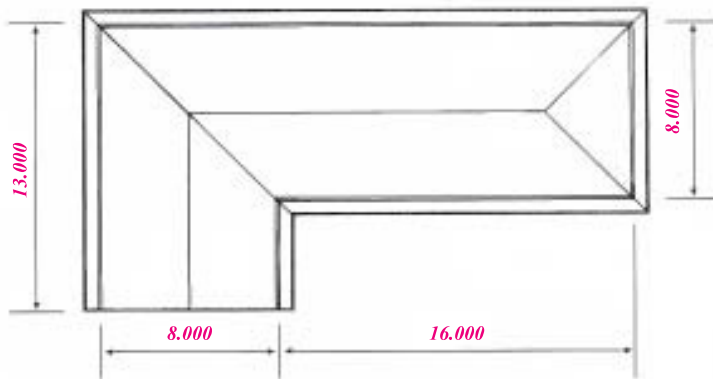

Figure 29a

Figure 29b

THREE DIMENSIONAL REPRESENTATION OF ROOF

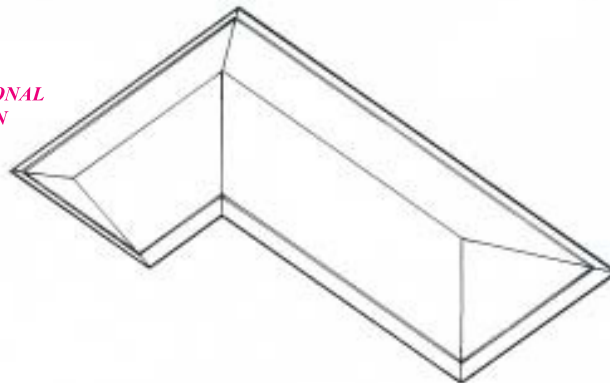
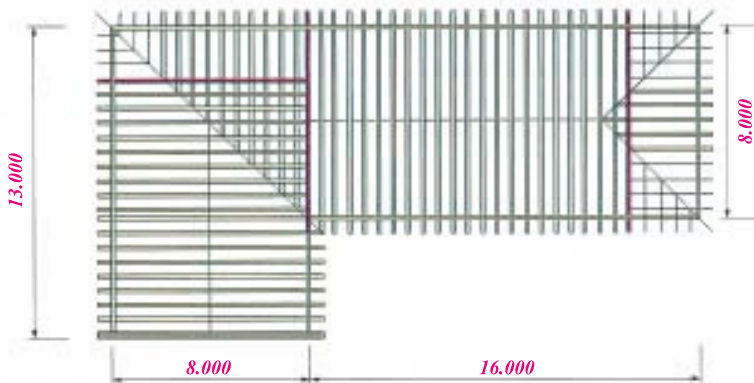

Figure 29c

FRAMING PLAN



Selecting Trussed Rafter Profiles

Figure 30a

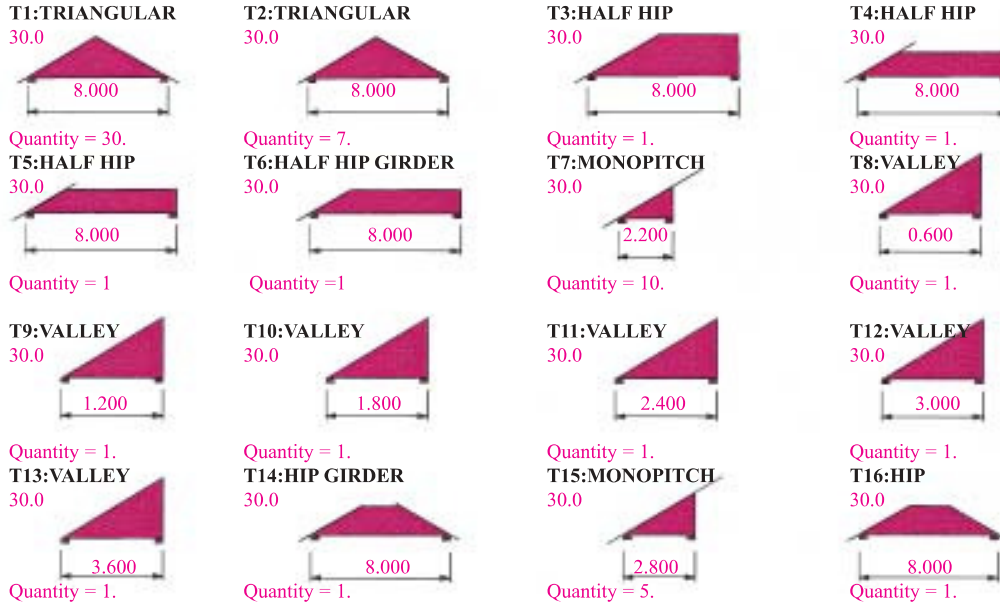

Another illustration of 'sectioning' to find the required profile would be the choice of either a cantilevered or

bobtail truss, as shown in the following figures.

Figure 30b

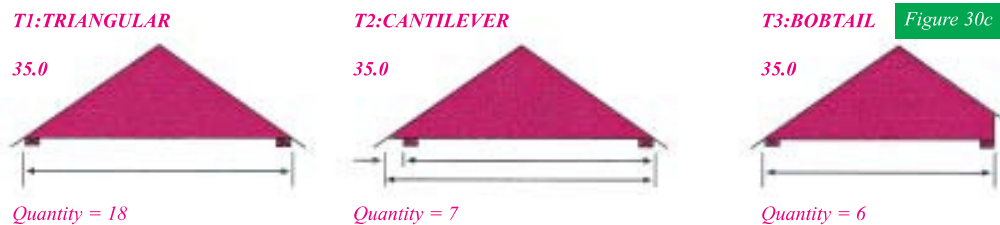
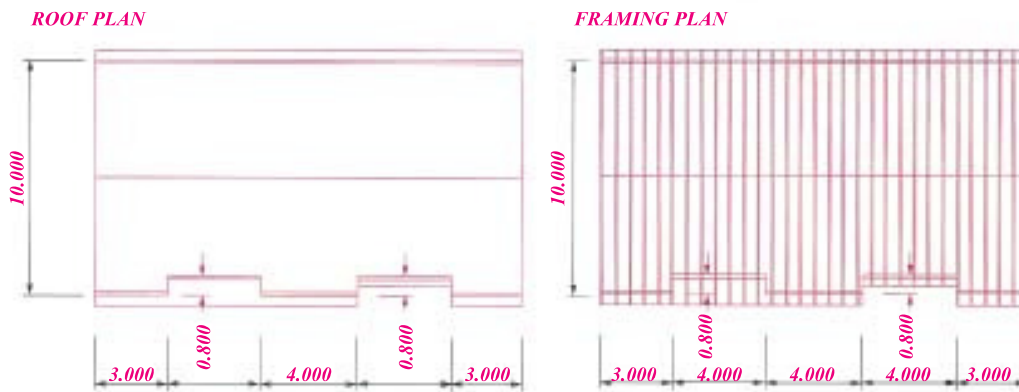

Figure 30c

As mentioned earlier, computer graphic programs are increasingly assisting the designer to visualise the roofscape.

The figures in this section have been produced from MiTek's MI2000 layout, take off and design software.

**Framing Common Roofscapes**

**Bobtail (Stub Ends)**

Bobtail or stub-end trusses are used where the supporting wall position on one or both sides is set in from the normal heel position. (see section 3.9, bearing details). This commonly occurs where recesses occur in the outside wall line of a building or where walls are built up to tile level to provide a firebreak compartment within the building.

The horizontal 'A' dimension (figure 32), known as the cut-back, is therefore conveniently used to specify the shape for duo-pitch trusses, while double bobtailed trusses and bobtailed mono-pitched trusses are often more conveniently specified by a vertical 'A' dimension, known as the End Height.

Figure 31

EFFECT OF BOBTAIL ON ROOF LINE

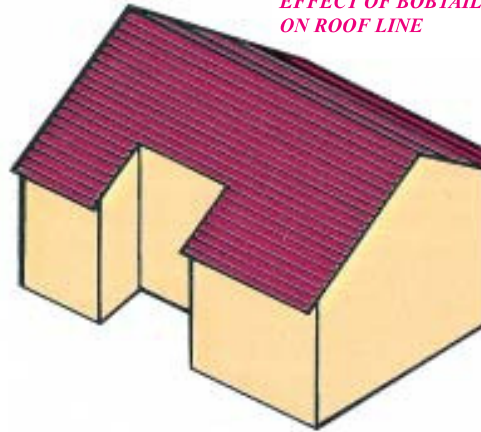

Figure 32

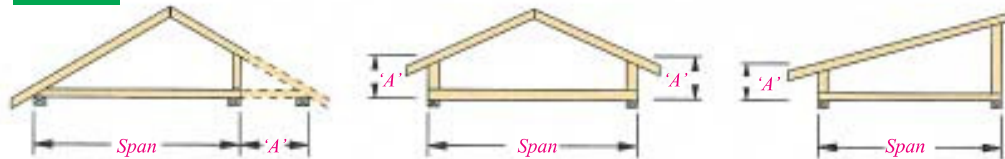
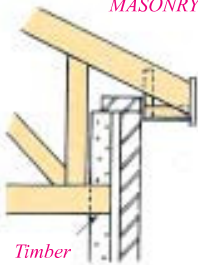

Figure 33 shows typical end details when the outer leaf is of masonry. Arrangement 33b is best confined to timber frame construction as separate columns of masonry between trusses could be unstable. There should be sufficient depth of masonry on figure 33a to anchor the roof down against wind uplift. If the end verticals are to be tile clad, one of the arrangements in figures 33c or d is suitable. In figure 33c a specially wide timber is used as the end vertical

of the trusses so that the tile battens clear the outer leaf of the wall; the inside of the end vertical member of the truss must not be located to the right of the centre-line of the wallplate. In some cases this arrangement is impractical owing to the large width required for the end vertical. In many cases the diagonal in the cantilevered part (figure 33d) can be omitted if there is little load from the cladding.

Figure 33a

MASONRY OUTER LEAF



Timber nib

Figure 33b

Masonry inner leaf

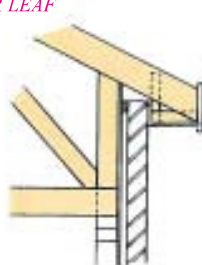

Timber frame

Figure 33c

TILE CLAD END VERTICAL



Figure 33d

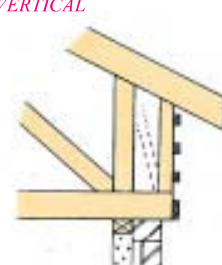

Bobtailed trusses must never be formed through on-site modifications of standard truss types with which they align, following the basic rule that a trussed

rafter should never be cut, notched, drilled or otherwise modified without first checking with the Trussed Rafter Designer.



## Framing Common Roofscapes

### Cantilevered Trusses

The reaction from the bearing is the greatest load (although upwards) to which a truss is subjected, and in order to control excessive bending in the supported chord, it is important, except in the smallest trusses, to locate a joint at each bearing. The normal eaves joint (figure 34a) accomplishes this if the bearing shift is less than one-third of the scarf length or is less than 50mm.

If the shift is greater than the allowed a stress check is required on the short cantilever. Unfortunately, there is often insufficient space for an additional web so it is usually necessary to increase the bottom chord (figure 34c) or alternatively, to incorporate a relief rafter (figure 34d) or a heel wedge. Both of these options can add to the final costs of the trusses and therefore it is best to avoid cantilevering the trusses in this range.

Figure 34a

Standard truss

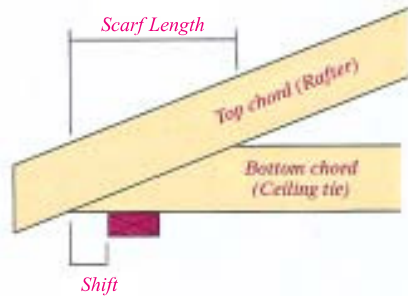

Check bottom chord

Figure 34b

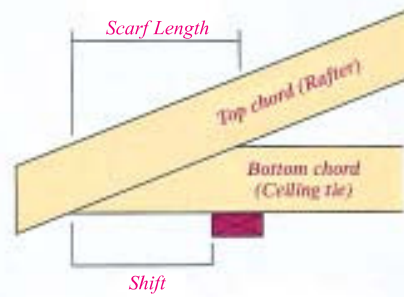

If the shift is greater than two scarf lengths, then an ordinary standard cantilever truss is employed. (fig35)

position of the joint on a non-cantilevered standard truss type, so that it is over a bearing.

Note that the chord sizes are not normally greater than the corresponding non-cantilevered standard truss and the cost is very little more. The MiTek system offers many standard cantilevered truss types. Many other variations are possible by adjusting the

Finally, if required a non-standard cantilever truss of almost any triangulated configuration can be designed and fabricated. Note that a brace may sometimes be needed on the bottom chord, which is untypically in compression.

Figure 34c



Figure 34d



Figure 35

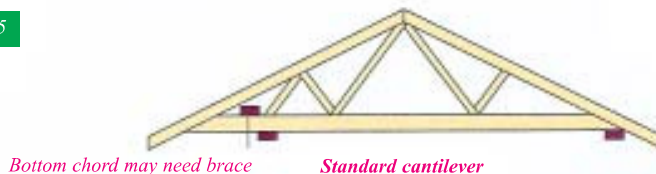

### Framing Common Roofscapes

#### Typical Roof Features - Hipped Ends

The most common end shapes are the Gable End, which allows the simplest roof framing and uses most support wall surface; the Hipped End which offers a simple wall solution at the expense of a more

complex roof structure, and the Dutch Hip and Gable Hip, which are compromises between a gable and hip, easily formed using trussed rafters.

Figure 36a

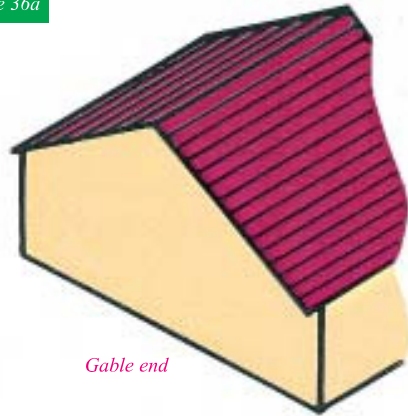

Gable end

Figure 36b

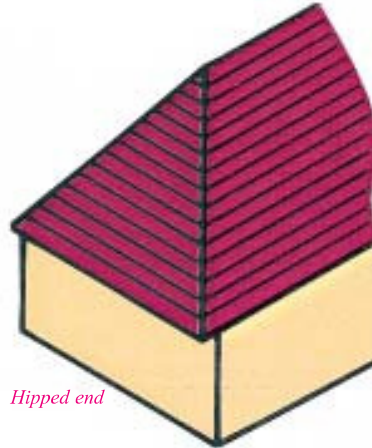

Hipped end

Figure 36c

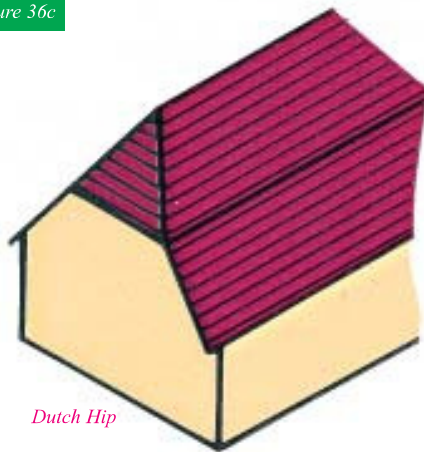

Dutch Hip

Figure 36d

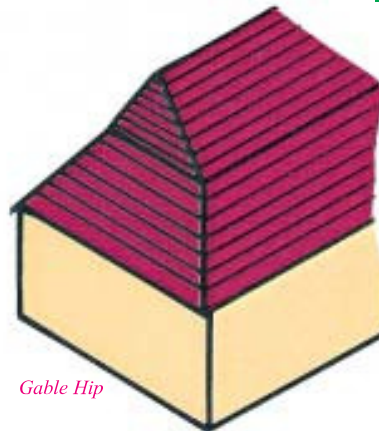

Gable Hip

Figure 37a



Action of hip end

Figure 37b



Traditional hipped end

Most traditional hipped ends behave like an inverted conical basket and, under load, the tendency for its rim (the wall plate) to spread is resisted by friction (lateral force on the wall), tension in the rim (tension and bending in the wall plate) and tension in the weft (the tiling battens). In the long term the results are sagging hip boards and rafters, bulging walls and characteristic horizontal cracks in the masonry at the inside corners of the dwellings roughly 300-600mm below ceiling level.

However, hipped end systems develop by MiTek do not depend on tension in battens, or a massive wallplate and horizontal resistance from the walls. With suitable bracing, the trussed rafter hip roof provides the walls with the stability required by Building Regulations.

## Framing Common Roofscapes

### Hipped Ends

The simplest form of hipped end consists of a multi-ply girder of standard trusses securely nailed or bolted together, which support loose rafters and ceiling joists, as in figure 38.

This is the most inexpensive form of hip because no special trusses are needed other than the girder, but their use is limited to spans up to 5m.

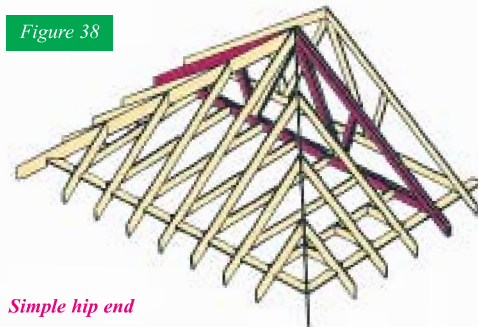

Loose rafter and ceiling joist sizes should be taken from Approved Document A to the Building Regulations. Hip boards should be supported off the girder by means of a ledger. The ceiling joists should be supported by proprietary joist hangers.

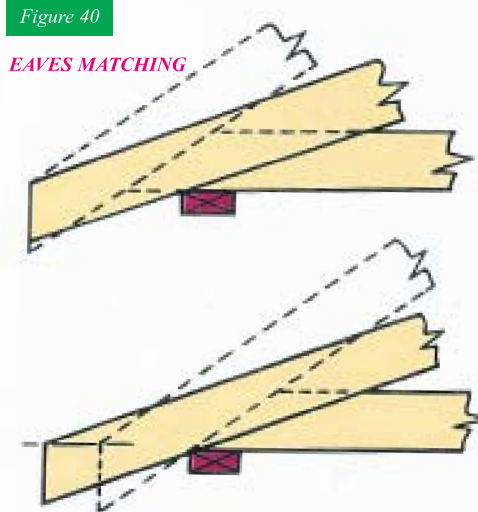
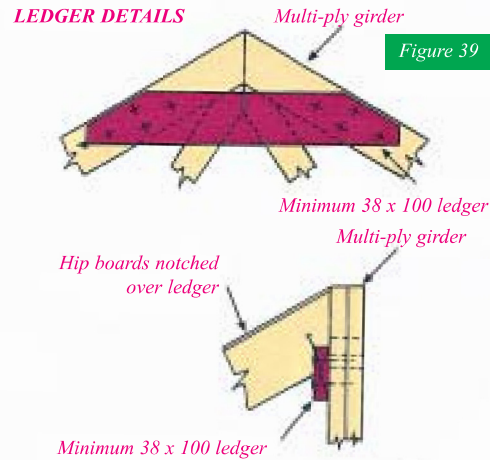

If the end pitch is different to the pitch of the main roof, the eaves details should be discussed with your trussed rafter supplier. It is advisable to ensure that the top extremities of rafter overhangs are at the same level to provide for continuous guttering. Note that whilst adjustments can be dealt with on site in loose timber construction, the mono-pitched trusses used in other hip types must be made correctly in the factory.

It should also be noted that all forms of hip construction employing a hip board exerts a horizontal thrust at the wallplate corner junction. Having taken up any horizontal movement, of course, the structure becomes stable. Movement of the wallplate can be controlled by fixing a 1200mm length of galvanised steel restraint strap around the outside. See figure 41.

MiTek trussed rafter suppliers can provide detailed advice on hipped end roof details.

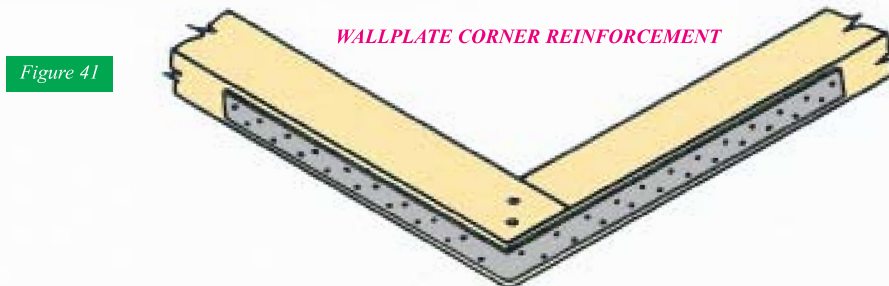

## Framing Common Roofscapes

### Hipped Ends - 'Stepdown'

The step-down hip system uses flat top hip trusses of progressively diminishing height from the ridge to the girder truss position. This system is rarely used as each truss is different to make. The number of step-down hip trusses is determined by the need to maintain reasonable sizes for the loose ceiling joists and hip board in the hipped corner infill areas. For these reasons, the span of mono-pitch trusses is not usually greater than 3 metres in the case of regular hips, where the hip end pitch is the same as the pitch of the main roof.

hip truss to support tiling battens. The web configuration of the various truss types shown (including the mono-pitch) are typical, but will be chosen to provide the best structural solution. Fortunately, this system is flexible in accommodating large spans and irregular hips with unequal roof pitches and employs standard, designed truss types throughout.

Noggings must be fitted between the flat chords of the step-down

Figure 42

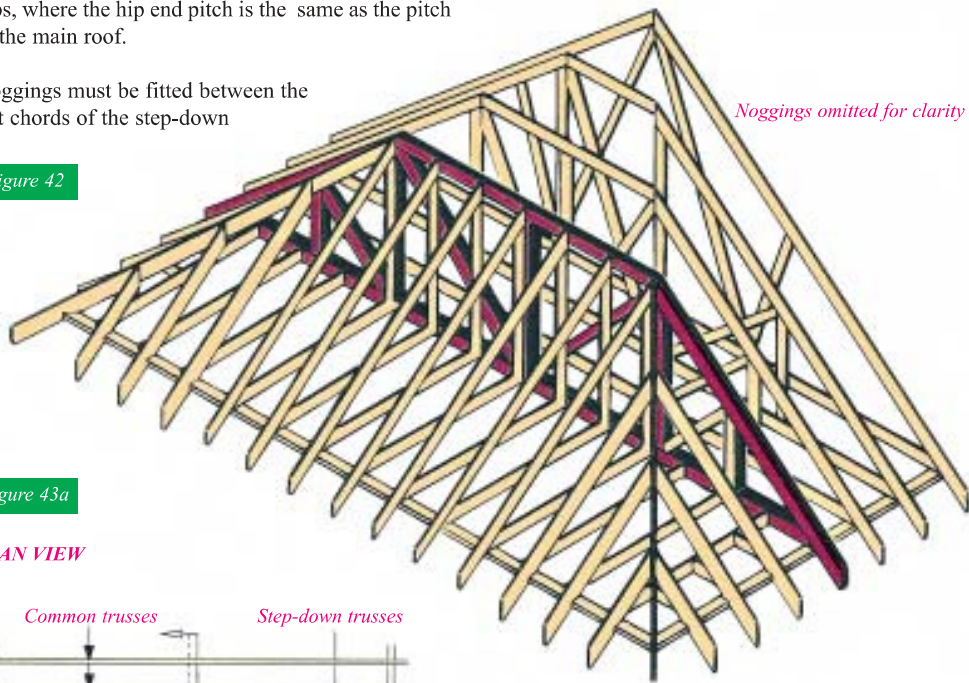

Figure 43a

#### PLAN VIEW

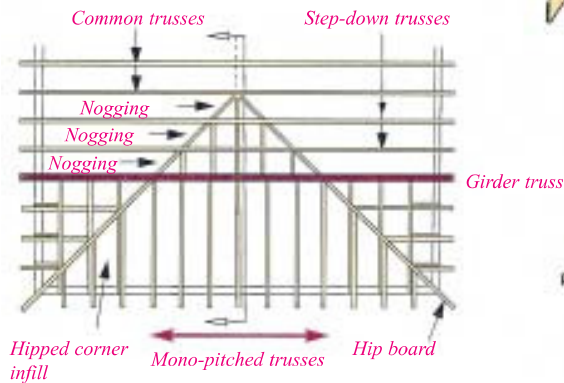

Figure 43b

#### SECTION

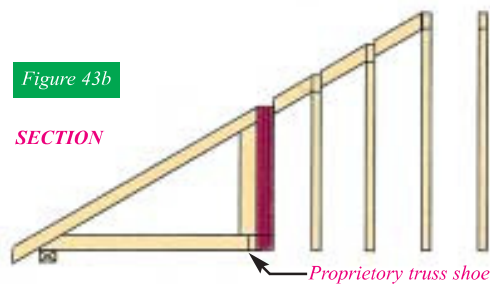
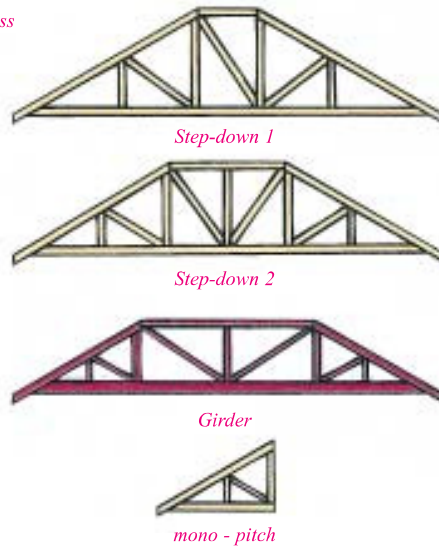

Figure 43c

#### TRUSS COMPONENTS



## Framing Common Roofscapes

### Hipped Ends - 'Flying Rafter'

Of the many types of hip systems this one has an obvious manufacturing advantage: There is only one basic hip truss profile. All the hip trusses, including those forming the girder truss are identical; and the mono-pitch trusses supported off the girder have the same profile as the sloped part of the hip trusses, which speeds up fabrication and reduces the overall cost of the hip system.

The rafters of the mono-pitched trusses and/or hip trusses are extended and are site cut to fit against the upper hip board. Off-cuts may be required to be nailed in position to the rafters of the hip trusses. For the longer rafters props may be required to run down to the trusses underneath.

The flat parts of the top chords of the hip trusses and girder must be securely braced together to ensure stability.

The hip corner may be constructed from pre-fabricated rafter/joist components commonly called Open Jacks or all the corner can be framed with loose rafters, joists and hipboards on site. The hip board is notched over the girder truss and supported off ledgers at the apex of the hip.

This system offers the advantage of continuous rafters and thus easily constructed smooth roof slopes.

Typical spans using this construction with one primary multi-ply hip girder is 5 - 9.6 metres.

Larger spans, up to 13.2 metres, may be accommodated by the use of intermediate girders between the main girder carrying the mono-pitch trusses and the hip apex.

It is possible to construct several types of hip end using the *'Flying Rafter'* concept, or indeed, to combine the *'Step-down'* concept within the hip trusses with the *'Flying Rafters'* on the hip end mono-pitch trusses.

Please contact your truss supplier if you have a preference for a particular method of construction, as the MiTek design system can encompass any method.

- 1 Flat top chords require bracing
- 2 Ledger under to support hip boards
- 3 'Flying Rafters' on hip trusses (may require props to trusses below)
- 4 Girder
- 5 Infill rafters
- 6 Hipboard
- 7 Infill ceiling joists
- 8 Mono-pitch trusses

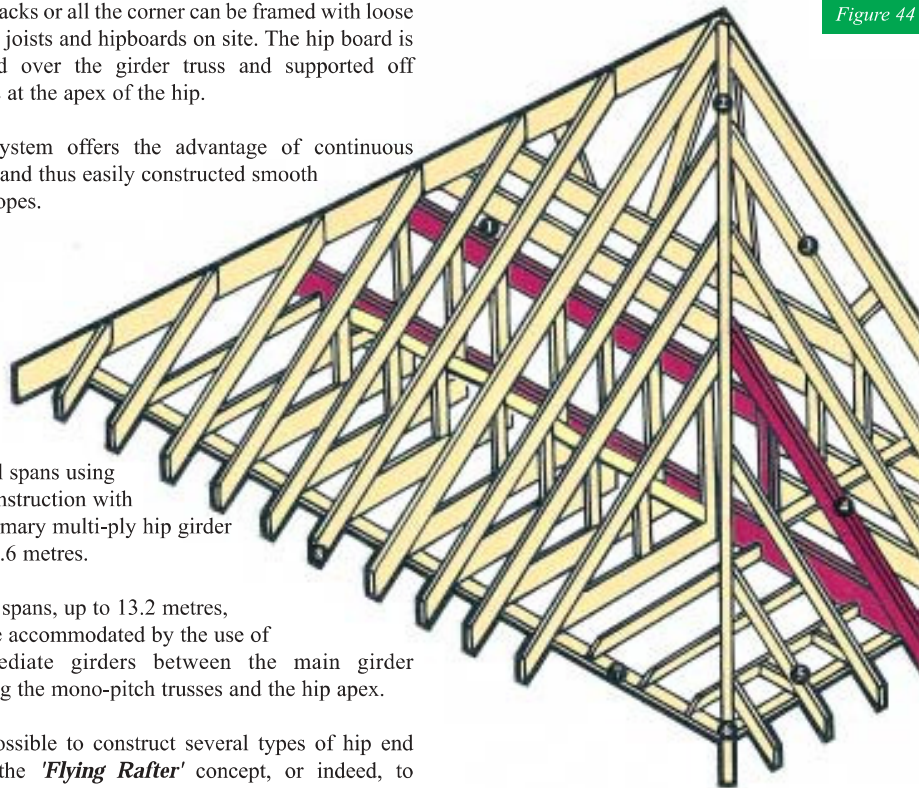

Figure 44

*Rafters omitted for clarity*

## Framing Common Roofscapes

### Hipped Corners

A hipped corner is formed by the intersection, at 90 degrees, of two roofs which may, or may not be the same span or pitch.

Figure 45

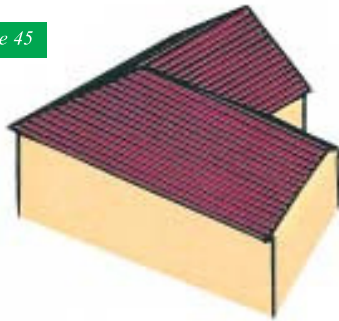

Hipped corners for mono-pitched and other roof shapes are based on the same principles described below for duo-pitched roofs.

The common framing consist of a SECONDARY half-hip girder truss supported by a PRIMARY duo-pitch girder truss. An internal load-bearing wall or beam support can often be used to perform the function of the primary girder truss.

The duo-pitch girder truss is specially designed for the exceptional loads it carries and includes a wider than normal vertical web to which a proprietary girder hanger can be fixed to carry the half-hip girder.

Figure 46b

PLAN VIEW

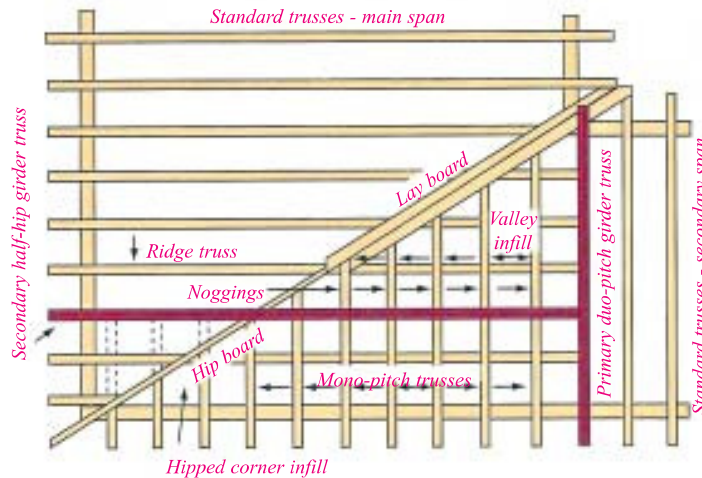

The roof is built up in the valley area using a mono-pitched valley set so that the half-hip girder carries the mono-pitch trusses and hipped corner infill, in the same way as at a hipped end. The span of the mono-pitch trusses is not generally greater than 3 metres and more than one half-hip truss may be needed between the ridge truss and the half-hip girder.

Figure 46a

### COMPONENTS OF HIPPED CORNER

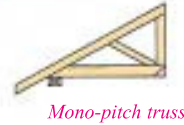
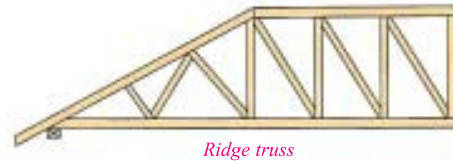
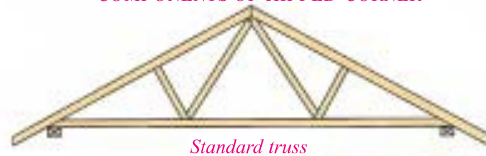

The details shown correspond to the method of construction used in the Step-down hipped end, in which noggings have to be sited between trusses to support the tiling battens.

Hipped corners with a Flying Rafter can also be provided.

### Framing Common Roofscapes

#### 'Tee' Intersections and Valley Infill

The basic junction of two roofs is known as a 'Tee' intersection, where a valley line will be formed at the point of intersection of the two sloping planes. The construction around the valley area is commonly formed by the use of either timber rafters, valleyboards and ridgeboards (not recommended) or by the use of pre-fabricated valley frames (Fig 47b).



Figure 47a

Figure 47b



It is strongly recommended that valley frames be used in junction areas, as these provide the quickest, cheapest and most structurally effective solution to the roof framing in these areas.

The use and function of the valley frames are more important than they appear. The individual components transfer the roof loadings to the top chords of the underlying standard trusses in a uniform manner. Acting with the tiling batten between each neighbouring pair of components, they provide lateral stability to the same chords.

Some variations on the basic system are shown in figure 49. Others occur from time to time and suitable layouts can be easily devised by MiTek trussed rafter suppliers.

The layboards shown in figure 48 are in short lengths and supported off battens nailed to the sides of the rafters, to lie flush with the tops of the rafters. This enables the felt and tiling battens to be carried through into the valley. The tile manufacturers advice should be sought to ensure correct tile and pitch suitability.

In many cases, the support for the main roof trusses may be provided by a multi-ply girder truss as shown in figure 48, with the incoming trusses supported in proprietary Girder Truss Shoes at each intersection.

It is common practice on site to erect the girder truss first and position the incoming trusses afterwards.

All MiTek girders are designed to resist stresses induced in the bottom chords by the supported trusses. The connector plates on girders will typically be considerably larger than those on the standard trussed rafters.

Figure 48

#### TEE INTERSECTIONS

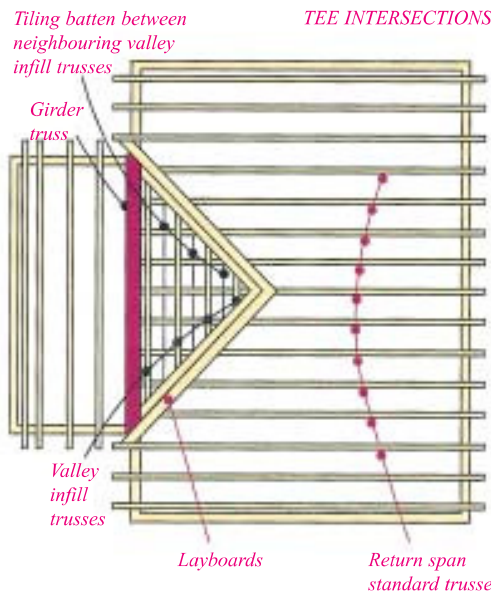

Figure 49



As described above, the valley construction should include intermediate tiling battens between neighbouring valley infill trusses, to provide the correct restraint for the rafters of the underlying trusses.

Figure 50



### Framing Common Roofscapes

#### Dog Leg or Skew Corners

A dog leg or skew corner is formed by the intersection of two roofs at an angle other than 90 degrees.

It is usual for the incoming and outgoing roofs to have the same span and pitch, although it is possible to frame the roof using trussed rafters, if these differ.

The cross section may be of any of the usual shapes but is generally mono-pitched or duo-pitched.

Figure 51

DOG LEG



Figure 52a

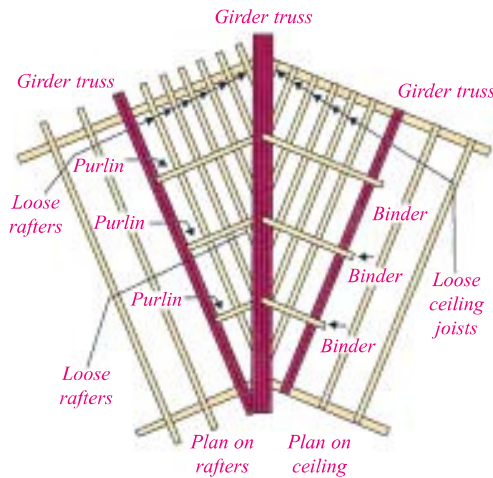

The typical framing plan shown for a duo-pitch roof is characterised by the minimum number of different truss types and provides a practical solution to the problems raised in these situations but using loose infill.

The multi-ply girders used have a number of vertical webs to allow the fixing of the loose timber purlins, which support loose timber rafters.

The example shown needs a lot of site loose work. However now that there are proprietary metal hangers available to join trusses to girders at angles other than 90 degrees the whole of the corner could be framed with trussed rafters.

Figure 52b

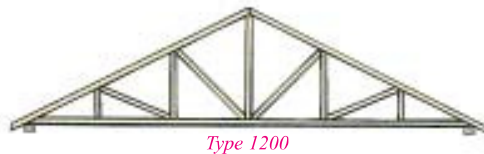
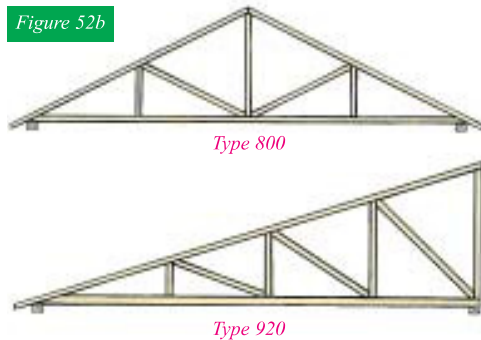

Figure 52c

The feasibility of this framing method depends on the design of the longest purlin. Although installation of loose ceiling ties from girder to girder may be simpler in carpentry requirements, it is generally preferable to adopt the layout shown (incorporating loose timber binders at ceiling level), in order to simplify plasterboarding.

The ceiling binders should be supported on the bottom chords of the girders and located against the vertical webs. A robust structural connection for example, with two proprietary angle plates should be made between binders and loose ceiling joints. The ends of the binders may need to be notched or blocked-up off the girders, to ensure that the undersides of the loose joists are level with the girders.

Loose rafters notched onto purlin

#### CONNECTIONS

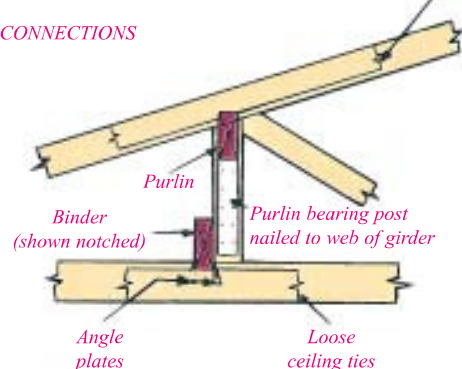



### Connection Details

Careful erection, fixing and strapping is essential if a trussed rafter roof is to provide a sound platform for roof coverings and contribute effectively to the stability of the roof and gable ends.

#### Strapping gables to ceiling ties

Ceiling tie straps may be excluded from the specification for roof pitches below 20 degrees. Check with the building designer. If they are needed, fix as shown for rafter straps, but attach to the upper edge of the ceiling tie. Use a twisted strap to engage a vertical joint if horizontal courses do not coincide.

#### Strapping at the separating wall

In addition to the normal strapping to walls, additional straps may have been specified to provide longitudinal bracing between roofs, these should be run over the top of the separating wall and fixed to the specified number of trusses on each side. Include noggings and packing to transmit loads properly.

#### Holding down roofs to walls

Roof to wall (vertical) strapping is not required unless the location of building construction is known to be wind stressed, then it is essential to carry out the roof designer's specifications. Lighter roof coverings in areas of higher wind load require holding down straps as may be specified for brick/block construction. In extreme cases the design may call for direct strapping of rafters to the walls (see figure 54).

Straps are normally 30 x 2.5mm section galvanised steel but any higher specification should be followed. The tops of the straps should be nailed (three 30 x 3.75mm nails or more) to the wall plate, or the rafter in the case of a rafter to wall strap. When fixing to the wall, it is critical that the straps are long enough to run over the specified number of blocks, and that at least two of the fixings engage the last full block at the base of the strap.

#### How to fix rafter straps

Engage at least three trusses with each strap. Use galvanised steel straps 30 x 5mm or approved profile galvanised steel straps.

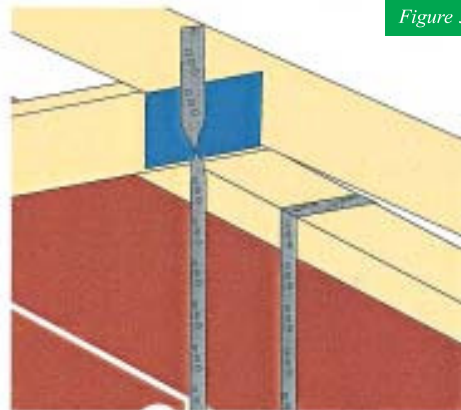
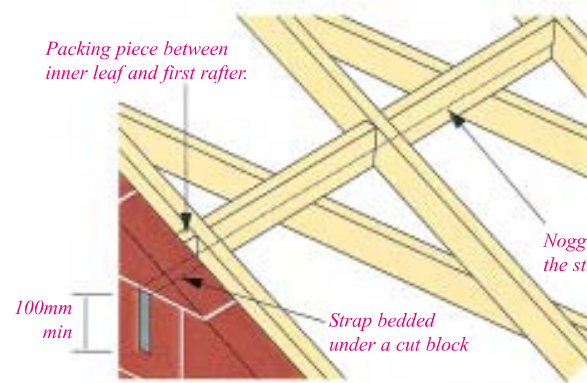

Figure 54

Figure 53



Packing piece between inner leaf and first rafter.

100mm min

Strap bedded under a cut block

Strap fixed to solid noggin with a minimum of four fixings of which at least one is to be in the third rafter or in a noggin beyond the third rafter

Use only corrosion resistant nails (65 x 3.35mm)

Noggings to be provided and set horizontal unless the strap has a twist to line it up with the roof slope.

## Connection Details

### Heavy-duty joist hanger to BS6178 Part 1

These are used to carry trusses or joists at masonry load bearing or fire break walls. Careful consideration must always be given to the method of support. We would recommend that advice is obtained from the responsible Building Designer or Structural Engineer since in a number of cases special hangers may have to be manufactured. The Building Designer may also specify high density brick courses above and below the hangers to avoid crushing of blocks. The bearing length for these joist hangers is approximately 90mm. (See figures 55 and 56).

*Hanger for building into brick or block walls*

Figure 55



### Heavy-duty girder to girder truss shoes

These are designed to support a secondary girder off the main girder ensuring that the loads are transferred efficiently. The shoe is usually fixed to the main girder (A) by means of bolts as specified by the manufacturer with washers under the bolt heads and nuts. The bearing length for these shoes is approximately 120mm. (See figure 57).

NB. Refer to manufacturers instructions for the correct application and procedure.



Figure 56

*Straddle hanger for supporting joists either side of a wall or beam*

### Girder truss shoe and long legged hangers

Girder truss shoes are used to fix single trusses to compound girders or for other truss connections. The bearing length is approximately 65mm.

The shoe or hanger must have side flanges of a size which suits the depth of the girder chord to which it is fixed. Some joist hangers are suitable only for timber or timber to truss connections not for truss to truss connections, always use the appropriate hanger. (See figure 58).

Metal fixings used in timber roof structures should have safe working loads which can be substantiated by freely available reports in accordance with BS6178 and TRADA recommendations. They should always have a manufacturer's mark and show the certified safe working load.

It is strongly recommended that timber to timber fixings and timber to brick fixings should be supplied by the Roof Truss Fabricator, and delivered to site with the trusses.

Figure 57

*Incoming trusses supported by bolted heavy duty shoes and hangers, should be notched to provide a smooth ceiling line*

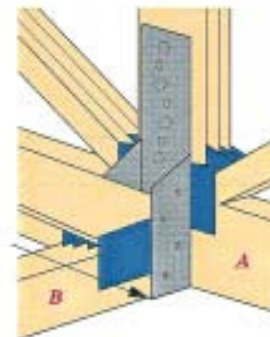
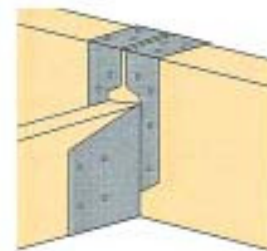

Figure 58



NB. For all the hangers and shoes described above, every fixing hole requires a 30 x 3.75mm square twisted sheradised nail unless otherwise specified by the manufacturer.

### Connection Details

#### Raised Tie Support Clip (Glide Shoe)

This is a special application fixing that has been specifically designed to allow horizontal movement at a truss bearing without affecting the overall stability of the truss whilst continuing to provide resistance to lateral and uplift forces.

Used in trussed rafter roof construction the (medium term/long term) horizontal deflection should be restricted to a maximum of 6mm per side (truss bearing). A minimum 100mm horizontal seat cut must be made to fix the upper bearing plate. The lower bearing plate is fixed to the inner (or inner and outer) edge of the wallplate using 3.75 x 30mm square twisted sheradised nails.

The truss is temporarily secured by single nailing into the centre slots to allow lateral spread between the bearing plates after the roof structure is completed. The longer the period of construction lasts, together with the absolute stiffness of the truss configuration, the greater the lateral movement will be (up to the design limit). Finally additional nails should be inserted (3.75 c 30mm long square twisted sheradised) for stability or uplift resistance in the remaining fixing holes.

Figure 59

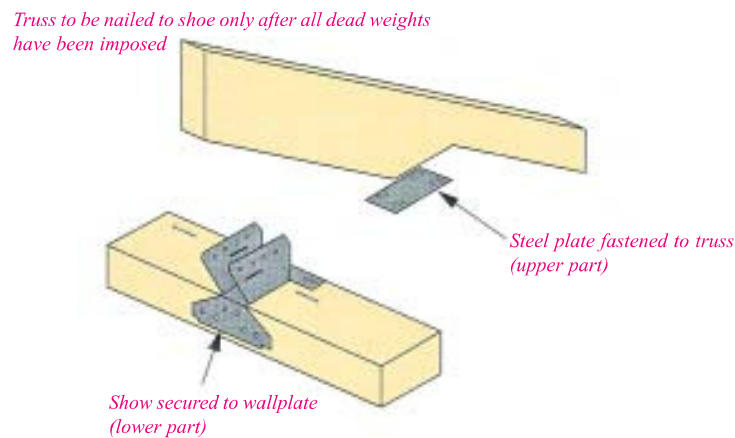

Connection Details

Figure 60

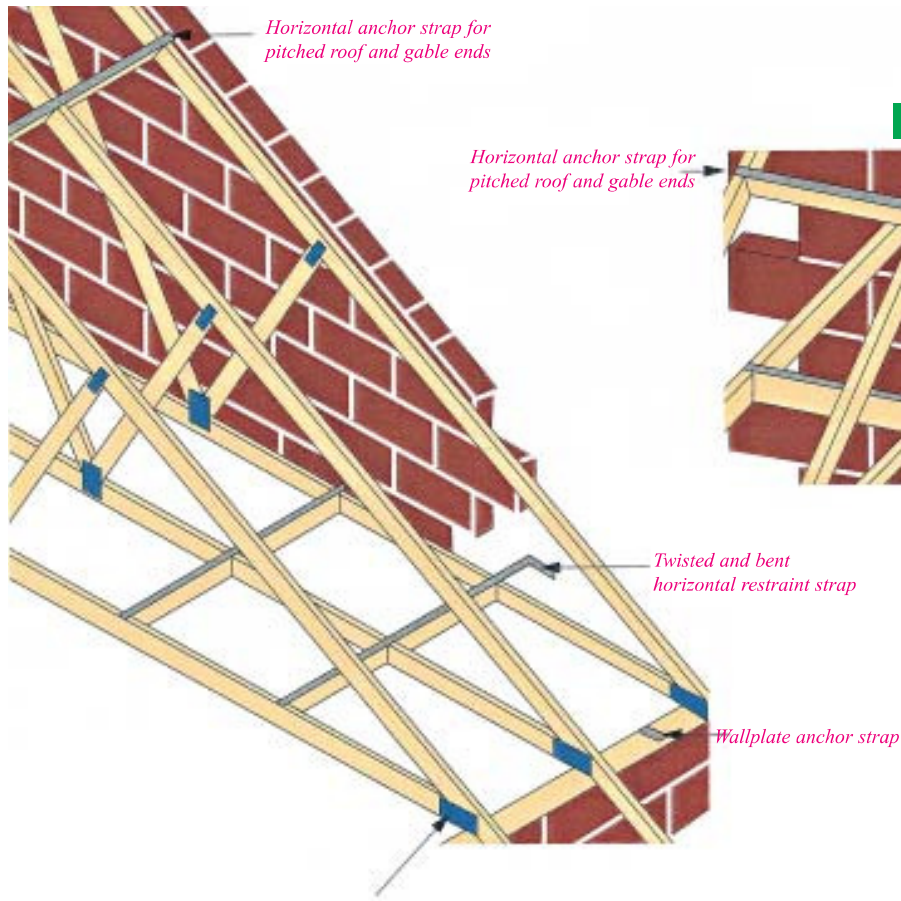

Horizontal anchor strap for pitched roof and gable ends

Horizontal anchor strap for pitched roof and gable ends

Twisted and bent horizontal restraint strap

Wallplate anchor strap

Truss clips are for fixing timber trusses to wallplates. They avoid the damage often caused by skew nailing. Follow the manufacturers recommendations for safe application of truss slip.

Figure 61



Figure 62

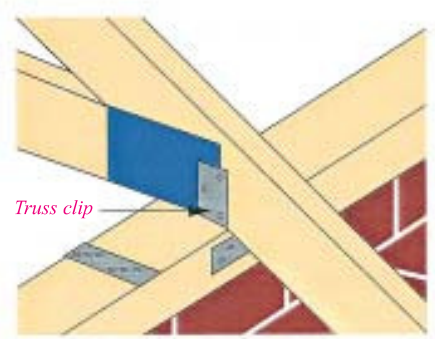

Truss clip

## Problems to be aware of

Some of the more common problems which may occur when designing roofs containing trussed rafters are listed below.

### 1. Trussed rafter or frame?

Trussed rafters are fully triangulated frameworks and there is often confusion when raised tie or Attic frames are required. Such frames are not fully triangulated trusses rafters, although they are of similar appearance, and their design calls for a completely different approach than that for true trussed rafters.

Figure 63

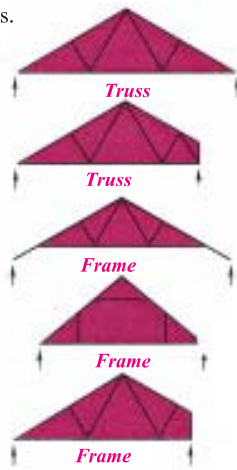

### 2. Trusses to match existing construction

Where trusses are required to align with existing roof constructions, great care must be taken to obtain the critical dimensions to which the new trusses should be made. The most common problems in this area are the misalignment of the outside rafter line and the mis-match of overall roof height.

Figure 64

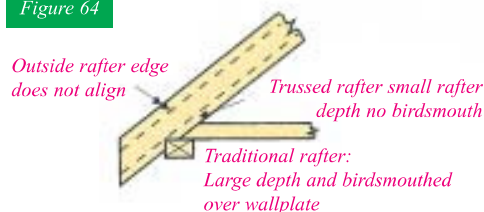

### 3. Changes in wall thickness

Trussed rafters are commonly supported on the inner leaf of a cavity wall construction. Where both inner and outer leaves of the masonry are required to support trusses (common when a garage abuts directly onto a bungalow for example), great care should be taken to ensure continuity of the outside rafter line.

Figure 65

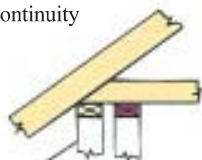

*If trusses are supported on outer leaf (or single skin wall) some trusses may require short cantilever details*

### 4. Changes in adjoining roof pitch

If two adjoining areas of roof are required to be at different pitches, care should be taken to ensure that the outside top edges of the rafter overhangs are of common height to provide continuity of fixing for fascia boards.

Figure 66

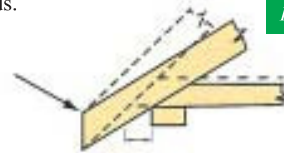

*Cantilever produced by change of pitch*

### 5. Variations in support conditions

It is increasingly common for the support conditions for trusses to be varied from the standard type of heel support, to create cantilevered and bobtailed (stub) trusses, where the cantilever or bobtail distance is short (in the order of 100 to 400mm). Such support conditions must be specially designed for, (See section 2.8).

### 6. Depth limits for trussed rafters

The general limit for the manufacture of roof trusses is in the order of 600mm overall depth minimum. Further, it is recommended that the span-to-depth ratio (span of truss divided by its overall depth) is not greater than 10. (See section 1.4).

### 7. Check that everything fits

Ensure that all water tanks, air-handling plant, services etc will fit within the outside profile and will clear the internal webs. A further point here, is to check that any deep hangers used to carry special loads will fit within the depth available to them, as such items tend to be relatively deep.

*Tank does not fit*

Figure 67



### 8. Fixings to support trusses

Timber to timber connections are best made at 90 degrees wherever possible, as angled connections increase costs. (See section 2.9).

### 9. Fixing of hangers

Where hangers are used on the bottom chords of girder trusses to support trusses and/or infill members, it is often more practical to provide a deeper bottom chord, usually 125mm or greater, in the girder truss to avoid the need for blocking-out on site.

Where hangers are used in masonry walls to carry trusses, a sufficient depth of masonry above the hanger should be provided to ensure a secure fixing. (See section 3.9).

### 10. Alignment of webs

In some cases, it is important to align webs on adjacent trusses within the roof to enable bracing members to continue in a straight line or for connections to be made from purlins. (See section 2.7).